

- 2-Independent pulse count inputs with a 0-36 VDC input range.
- Simultaneous interpretation of each input as frequency, pulse-count accumulator, or discrete input.
- **Operates from 12 VDC, 24VDC, 48VDC and 24VAC power supply rails. Power input is not polarity sensitive**
- **The Model 2200A is firmware compatible with our previous Model 2200.**
- Frequency measurement range to 40 KHz. Frequency measurement can be averaged over multiple samples. Additional input filter can be enabled to limit input to 400 Hz when interfacing with relay type dry contacts.
- Internal pulse accumulator has a capacity of 2,147,483,648 counts. Pulse input can be scaled.
- Configurable pull-up and pull-down circuit on each input. Threshold and hysteresis voltages for each input can be setup by user via the network.
- Compact DIN Rail mount enclosure that is only 36 mm (1.42") W x 90 mm (3.54") L x 58 mm (2.28") H.

DESCRIPTION

The Model 2200A is a Pulse Count Input Network Node that is housed in a compact DIN rail enclosure. It allows integration of up to 2 digital pulse inputs into the LonWorks distributed digital network. Input devices such as relays, conditioned proximity sensors, conditioned capacitive sensors as well as ultrasonic sensors are all supported.

The Model 2200A has a flexible front-end that supports direct wiring of NPN, PNP, TTL, as well as dry-contact type inputs. Pull-up resistor, pull-down resistor, threshold voltage, hysteresis voltage, and signal inversion can all be changed via configuration network variables.

Added to the flexible hardware front-end is a very flexible firmware layer. The firmware simultaneously calculates the accumulated pulse count, frequency, and, for steady state signals, allows the discrete digital state to be read. The frequency measurement rate is in excess of 40 KHz and the accumulated pulse count can be up to 2,147,483,648. The pulse accumulator can be scaled in such a way as to allow multiple pulses to be counted as a single event. The frequency input can be averaged over multiple samples. Finally, to allow a smooth interface with LonWorks devices, the frequency and count data is



- All data is available using Standard Network Variables (SNVT)

also available as a percentage of a user-configurable range.

Using the Model 2200A allows multiple sensors to be used over a simple four-wire bus installation. Two wires are used for power, the other are used for digital communication. The communication interface is the FTT-10 transceiver.

All connections to the Model 2200A are made via high quality removable terminal blocks. Power into the Model 2200A is reverse voltage protected, individually fused, and finally made available to the sensor terminal blocks. This feature allows simple power distribution to each pulse output device.

NOTE

This PDF datasheet has attachments. To access them, it may be necessary to use an actual Adobe Reader. since some readers built into internet browsers do not allow access to attachments.

Power Supply

The Model 2200A features an exceptionally flexible switching power supply. It allows the Model 2200A to be easily integrated into building automation, industrial

automation, telecommunication and remote telemetry type systems. It operates from 12 VDC, 24 VDC, 48 VDC and 24 VAC power supply rails with a design margin better than +/-25% to allow for installation variations. A main advantage of the on board power supply is low power consumption. The unit draws less than 10 mA at 24 VDC. This makes it ideal for low cost battery backup systems if one is desired.

The power supply is well protected against overvoltage spikes via solid state transient voltage suppressors. It is additionally protected against over current conditions via fuses on both voltage input lines. On board thermal fuses do not have to be replaced. They will simply recover when the fault condition is corrected. Input voltage is polarity insensitive.

WIRING AND INSTALLATION

Input power and network communication is done via a sigle 4-position terminal block at the upper end of the enclosure. Please see the wiring table below for attaching power and network wiring.

Each pulse input is attached to the Model 2200A via a 2-position removable terminal block on the lower portion of the enclosure.

The on-board Service switch and LED allow installation on to the LonWorks network. The Service LED and switch are in the upper right hand corner

Please see the table below for identification of each position on the terminal blocks. Please see the following sections for a complete explanation of how the Model 2200A processes the input signal as well as wiring diagram for different input types.

Upper Terminal Block	Connection
NET(2)	Position labeled Net connects the Model 2200A to the LonWorks FTT-10 network. These wires are not polarity sensitive.
VIN(2)	Positions labeled VIN connect the power supply to the Model 2200A. Not polarity sensitive and accept a wide input voltage range of DC and AC voltages. 9 to 55 VDC or 12 to 39 VAC at 0.25W maximum.

Lower Terminal Blocks	Connection
Note: Left = Channel 1, Right = Chanel 2	
IN +	Positive connection of input signal. Please see the wiring diagrams that follow.
IN -	Negative connection of input signal. Please see wiring diagrams below.

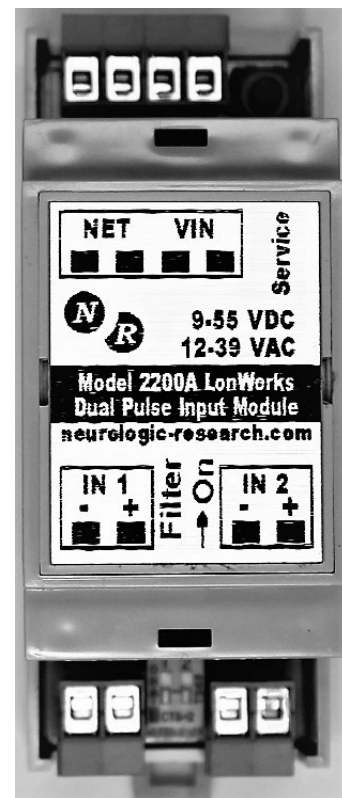

HOW THE INPUT SIGNAL IS PROCESSED

A block diagram of the input circuit and the input signal path is shown in Figure 1. Please note, that the name, nciXxxx, of the Configuration Network Variable controlling each specific feature is shown. The default values are shown in parenthesis. Figure 2 shows how the Input Signal Processing block processes the input signal. Please note, by default the counting is done on

the high to low signal transition and a signal above the threshold voltage considered OFF. This is done to accommodate the more common input types: dry contact, sinking or NPN. This can be changed by Setting nciInvert to 'ON':

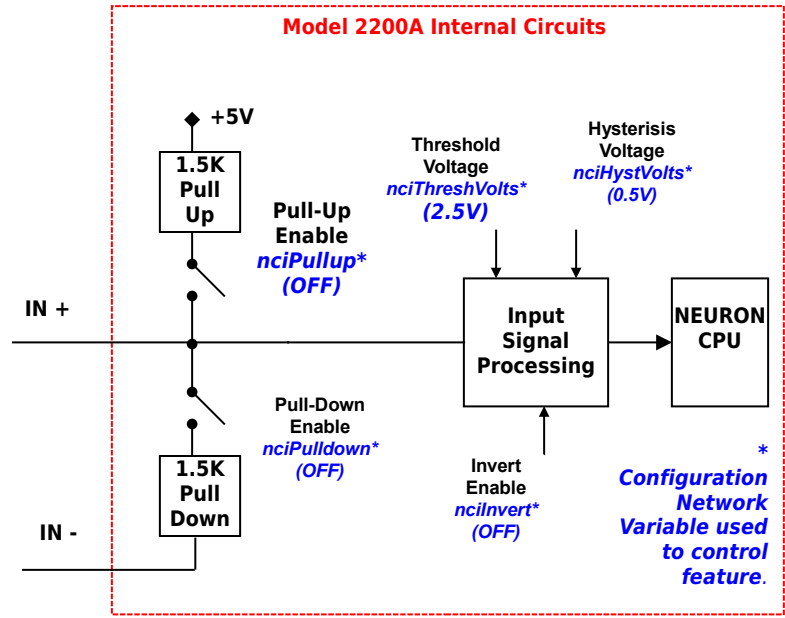

Figure 1: Model 2200A's Internal Block Diagram of Each Channel

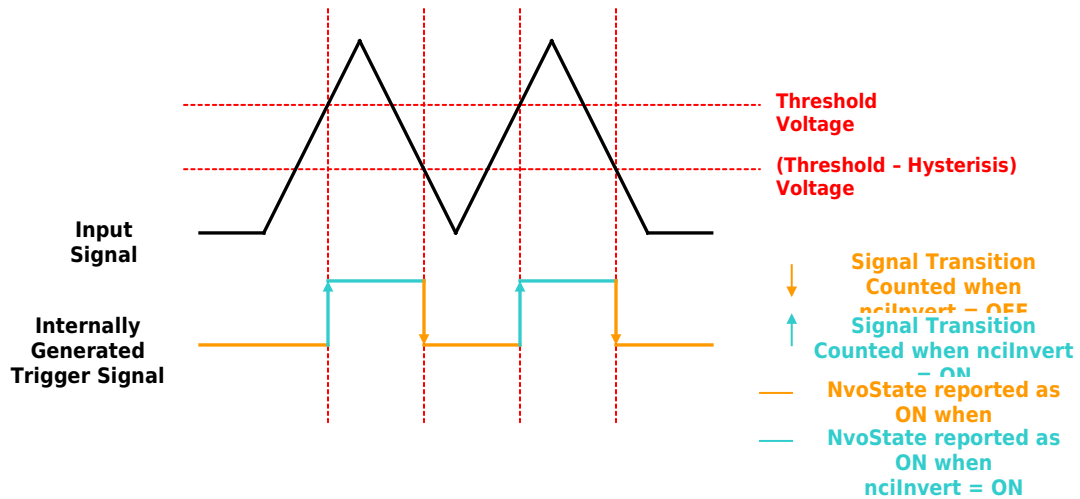

Figure 2: Model 2200 Processing of Input Signal

Dry Contact Input Interface

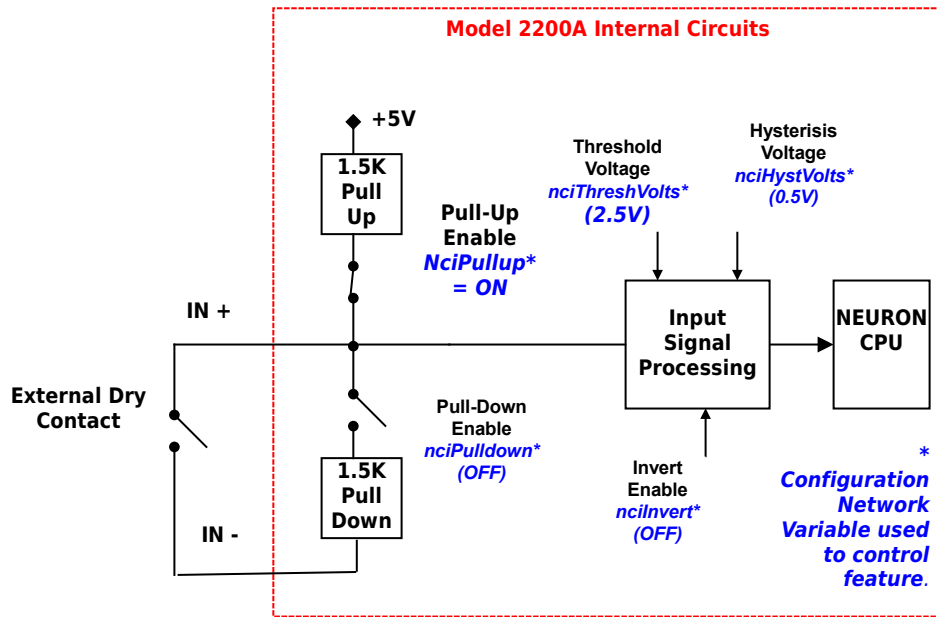

Figure 3: Dry Contact Connection and Configuration Network Variable Setup

NPN (Sinking) Input Interface

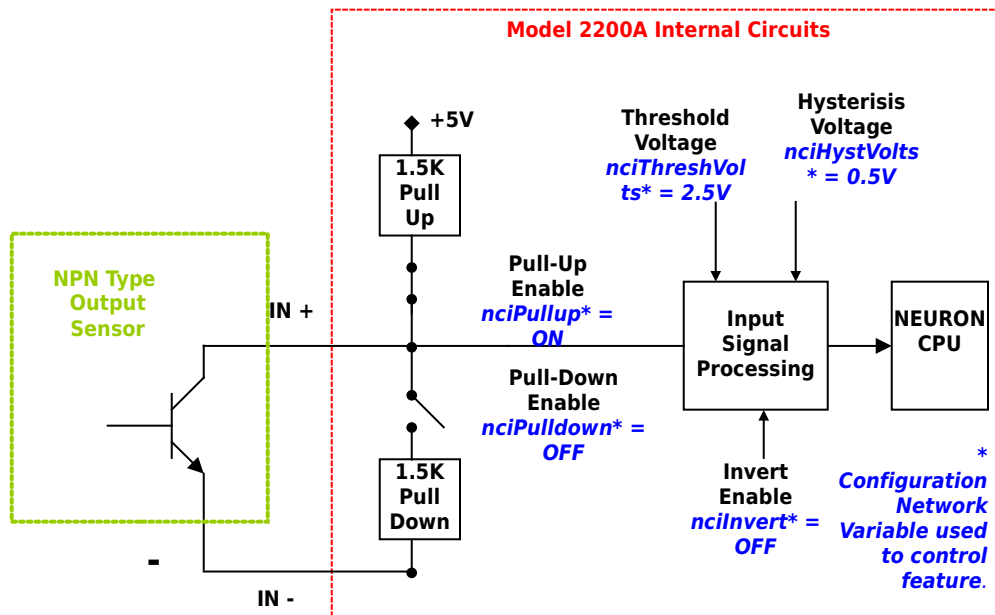

Figure 4: NPN (Sinking) Sensor Connection and Configuration Network Variable Setup

PNP (Sourcing) Input Interface

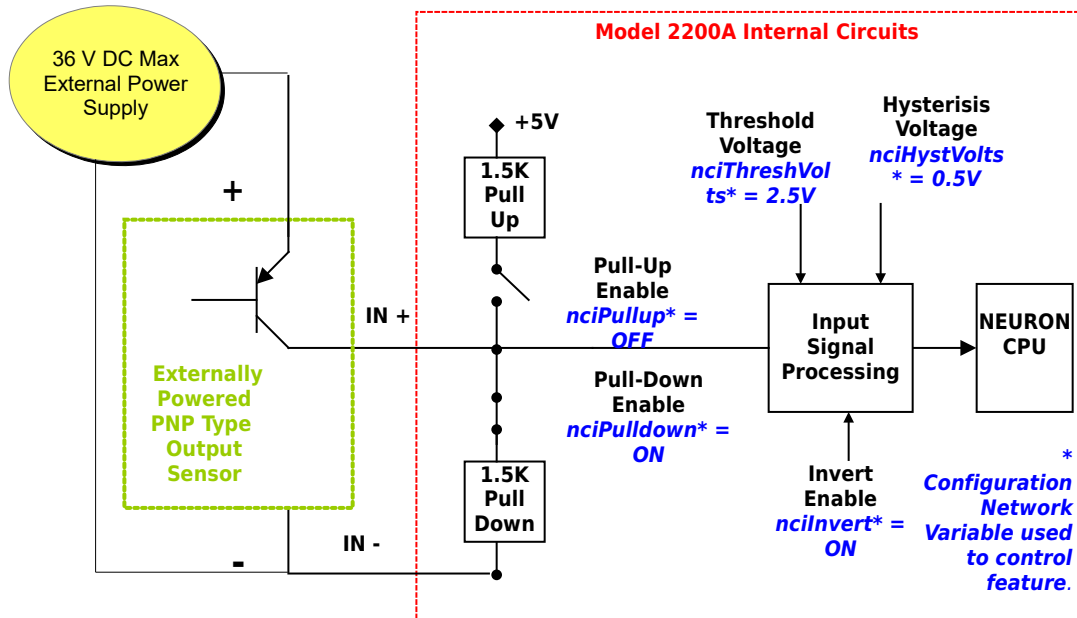

Figure 5: PNP (Sourcing) Sensor Connection and Configuration Network Variable Setup

TTL / Frequency Generator Input Interface

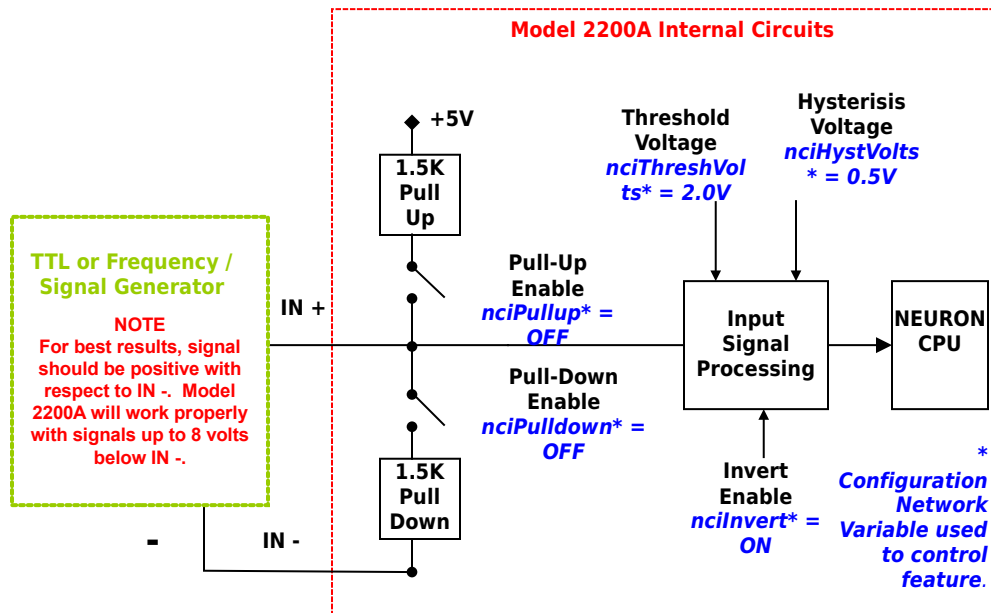

Figure 6: TTL or Frequency Generator Connection and Configuration Network Variable Setup

How The Pulse Accumulator Works

The internal pulse accumulator has a count capacity of 2,147,483,648. It can handle high-speed pulse trains with a period down to 15 microseconds. However, the pulse width must be at least 1 microsecond wide. By default, the Model 2200A counts the high to low pulse transition. See the section titled “How the Input Signal is Processed” for more detail. This can be inverted by setting the nciInvert Configuration Network Variable to ‘ON’.

The Standard Network Variable Type of SNVT_count has a capacity of only 65535. This data is available using the nvoCount network variable. When the maximum value is reached, the nvoCount will rollover and start again from 0. The Model 2200A makes a second network variable available, nvoRolloverCount. It will increment once each time the nvoCount value rolls over. By looking at both values, very large count accumulations can be realized. The actual value of the total count is $nvoRolloverCount * 65535 + nvoCount$.

Another feature of the pulse accumulator is that it can be scaled down using the nciCountScale Configuration Network Variable. This feature allows multiple pulses

How Frequency Measurement Works

Frequency is calculated approximately once per second for both channels. The hardware supports frequency input in excess of 65 KHz. There are two types of standard network variables used to express frequency: SNVT_freq_hz and SNVT_freq_kilohz. The SNVT_freq_hz value has a range of 0 to 6553.5 with 0.1 Hz resolution. The SNVT_freq_kilohz network variable type has a range of 0 to 6553.5 KHz with 0.1 KHz resolution. The Model 2200A supports both since neither one alone can handle the frequency measurement range of the Model 2200A’s firmware.

The nvoFreqHz network variable is used to read the frequency if it is less than 6553.5 Hz. If the input frequency is higher than 6553.5 Hz, nvoFreqHz will be set to its maximum value of 6553.5 and higher frequencies can be read using the nvoFreqKiloHz network variable.

Multiple frequency measurements can be averaged over 1 to 8 samples. Use the nciFreqAvgSize Configuration Network Variable to change it. The default is 3. The Model 2200A is accurate within 0.5 Hz with 3 samples and 1 Hz with no averaging.

to be reported as a single count. For example, if you want to count every 5 physical pulses as a single event, simply set nciCountScale to 5. The nvoCount network variable will then report the internal count divided by 5. nciCountScale can actually be changed on the fly. For example, if you operate the unit with nciCountScale at 5 and then realize it should really be a 3, simply change it to 3. nvoCount will then report the correct value for a scale of 3.

The firmware also supports reporting the count as a percentage value via the nvoPcntCount network variable. The percentage value returned is the value of nvoCount as a percentage of the nciMaxCount Configuration Network Variable. By default, this value is set to 65535. However, it can be changed. This is handy when interfacing to other LonWorks devices that may not support the SNVT_count type network variable.

Finally, the user can actually reset the count to any starting value by writing to the nviCountStart value. When this value is written, the actual internal accumulator is updated with the value written into nviCountStart multiplied by the nciCountScale value.

The firmware also supports reporting the frequency as a percentage value via the nvoPcntFreq network variable. The percentage value returned is a percentage scaled between two values set by the following Configuration Network Variables: nciMinFreq and nciMaxFreq. The defaults are 0 and 1000 respectively but can be changed by the user. This is handy when interfacing to other LonWorks devices that may not support the SNVT_freq_hz or SNVT_freq_kilohz network variable types.

Looking at Input as a Discrete Digital

For steady state input signals, the nvoState network variable reports the ON / OFF state of the input signal. The digital state is sampled by the firmware 10 times per second.

By default nvoState will report the OFF condition when the input voltage is above the nciThreshVolts value. This can be reversed by setting nciInvert to ON. Factory default for nciThreshVolts is 2.5 volts but can be changed between 0.3 volts and 5 volts. Please see Figure 1 and 2 for more detail.

NETWORK INTERFACE

The Model 2200A uses the Echelon FT-10 network transceiver interface with DC blocking capacitor so it can also be directly connected to LPT-10 networks. Before the Model 2200A can be used, it must first be installed into a LonWorks network. This procedure is slightly different for each system. It often involves telling the system to add a new device. The system will then ask the user to press the Service button on the device. When pressed, the Model 2200A will transmit its unique physical Neuron ID. The System then assigns a logical address to the unit and then data from the device is available. The data is available using Standard Network Variable formats that have been defined by the LonMark Association. The Model 2200A has self documentation of the network interface enabled and it can be uploaded by the installation tool. Additionally, an XIF is also attached to this PDF datasheet.

NOTE

The Model 2200A is firmware compatible with our previous Model 2200 firmware. If you purchased a Model 2200APM, 2200AVM or 2200A they can be converted to the type described in this datasheet by downloading the attached .NXE file over the LonWorks network. This is accomplished using your network installation tool when you install the device. If your network tool does not support this function we can do this for you at the factory, please contact us.

NOTE

This PDF datasheet has attachments. To access them, it may be necessary to use an actual Adobe Reader. since some readers built into internet browsers do not allow access to attachments.

Configuration Network Variables

Network Variable	Format	Drfault	Description
nciMinSendT	SNVT_time_sec	1.0 Sec	Minimum elapsed time before a network update is sent even if the configured delta change has been met.
nciMaxSendT	SNVT_time_sec	5.0 Sec	Maximum elapsed time before a network update whether or not the configured delta change has been met.
nciThreshVolts[2]	SNVT_volt	2.5 Volts	Sets the threshold voltage for the input trigger (see text) 0.12 to 5.0V
nciHystVolts[2]	SNVT_volt	0.5 Volts	Sets the hysteresis voltage for input to reset (see text) 0.08V minimum to nciThreshVolts[]-0.04V
nciInvert[2]	SNVT_lev_disc	ST_OFF = 0	Set to ST_ON to invert the input signal
nciPullup[2]	SNVT_lev_disc	ST_OFF = 0	Set to ST_ON to enable internal pull up resistor
nciPulldown[2]	SNVT_lev_disc	ST_OFF = 0	Set to ST_ON to enable pull down resistor
nciMinFreq[2]	SNVT_freq_kilohz	0.0 K Hz	0% Scaling for nvoPcntFreq[]
nciMaxFreq[2]	SNVT_freq_kilohz	1.0 K Hz	100% Scaling for nvoPcntFreq[]
nciFreqSndDelta[2]	SNVT_freq_hz	10 Hz	Minimum change before nvoPcntFreq[], nvoFreqHz[] and nvoFreqKiloHz[] are updated
nciFreqAvgSize[2]	Unsigned 1 byte integer	3	See "Howe Frequency Measurement Works" Section. 1- 8 is valid
nciCountScale[2]	SNVT_count	1	See "How the Pils Accumulator Works" Section.
nciMaxCount[2]	SNVT_count	65535	100% sccaling for nvoPcntCount[]
nciCountSndDelta[2]	SNVT_count	5	Minimum change before nvoCount[], nvoCountOverflow[] and nvoPcntCount[] are updated



Output Network Variables

Network Variable	Format	Description
nvoPentFreq[2]	SNVT_lev_percent	Measured Frequency scaled between nciMinFreq[] and nciMaxFreq
nvoFreqHz[2]	SNVT_freq_hz	Measured Frequency in Hertz
nvoFreqKiloHz[2]	SNVT_freq_kilohz	Measured frequency in kilo Hertz
nvoPentCount[2]	SNVT_lev_percent	Accumulated count scaled between 0 and nciMaxCount[]
nvoCount[2]	SNVT_count	Accumulated raw count. Value is between 0 and 65535.
nvoCountOverflow[2]	SNVT_count	Number of time nvoCount[] overflows. Total accumulated count is nvoCountOverflow*65536 + nvoCount
nvoState[2]	SNVT_lev_disc	Status of the discrete input. Can be used for diagnostics or to interface to standard switch closure

Input Network Variables

Network Variable	Format	Description
nviCountStart[2]	SNVT_count	Allows the nvoCount[] accumulator to be reset or started at any value.

SPECIFICATION

General

CPU	Neuron FT5000
Operating Temperature	-40 – 85 C
Operating Humidity	0-95% Relative Humidity non-condensing
Input Power	9 to 55 VDC or 12 to 39 VAC at 0.25W maximum.
Input Power Protection	Input power is fused and transient voltage protected. (Fuses do not need to be replaced)
Network Transceiver Type	Removable terminal blocks. Accepts 14-26 GA wire. Input power is reverse voltage protected. Network wiring is polarity insensitive.
Input Power and Network Wiring	Removable terminal blocks. Accepts up to 14-26 GA wire. Input power is reverse voltage protected. Network wiring is polarity insensitive.

Inputs

Inputs	2
Input Types	Simultaneous frequency measurement, pulse accumulator, and discrete digital input
Input Voltage Range	0-36 VDC
Threshold Voltage Range	0.12 – 5 VDC Hardware and firmware limited
Hysteresis Voltage Range	0.08 to Threshold Voltage-0.1 VDC Hardware and firmware limited
Frequency Accuracy	+/- 1 Hz with no averaging. +/-0.5 Hz with 3 sample averaging
Frequency Averaging	1 – 8 samples
Frequency Measurement Range	40 Khz with filter off and 400 Hz with filter on using default threshold and hysteresis
Minimum pulse period	25 microsecond with filter off and 2.5 millisecond with filter on using default threshold and hysteresis
Pulse Accumulator Size	2,147,483,648
Pulse Accumulator Scaling	1-100
Software Update Frequency	All channels are processed once per second
Protection	Can tolerate up to +/- 40 VDC without damage. However, proper operation only guaranteed if input signal is limited to -8 volts below the IN- terminal.

Dimension and Materials

External Dimension	36 mm (1.8”) W x 90 mm (3.54”) L x 58 mm (2.28”) H
Enclosure Type	DIN rail mount to 35 mm rail
Enclosure Material	Grey frame retardant Noryl UL94 V0

ORDERING INFORMATION

2200A	Model 2200A LONWORKS DUAL PULSE COUNT INPUT
-------	---

Echelon, LON, LonWorks, Neuron, 3120, 3150, LONMARK are trademarks of Echelon Corporation.

